

CS & CL Electric Actuators

Conbraco's CS and CL electric actuators are split phase reversing AC motors for standard duty or brushless DC Motors for continuous duty. Eight sizes are available which produce break-away torques between 150 and 3000 lb-in. They are excellent industrial quality units capable of on/off, fail safe, and modulating applications. The efficient spur gear drive train is supported by permanently-lubricated bearings making it very secure while eliminating the potential for side loading of the output shaft.



Conbraco offers as standard a 75% duty cycle AC motor. Continuous-duty brushless DC motors are also available for a range of input voltages. All units are rated for use in ambient environments from -40°F (with optional heater & thermostat) to 150°F (note that units equipped with an internal battery are rated to 130°F). Choose from standard NEMA 4/4X enclosure or NEMA 4/4X/7&9 for use in hazardous locations. CSA certification is standard on standard 75% duty models.

Other standard features include:

- Thermal overload protection (AC motors)
- Dual conduit openings; 3/4" (1/2" with supplied bushings)
- Visual position indication
- All aluminum enclosure
- Captive cover bolts on CS Series
- Manual override shaft (optional handwheel override with declutchable shaft)

- Features-

- Plug-in connectors for the motor, the brake option and the heater/thermostat option
- All connectors are coded to prevent mis-wiring.
- Limit switch wires are soldered to the board - no more loose connections.
- A six position terminal strip clearly labeled so it can be wired up in the field without an instruction manual.

Introducing Simplicity for Calibrating Modulating Actuators

The Control Board brings a whole new level of simplicity to the field. It will work with either of the Motor Boards (115VAC or 230VAC). Features include:

- Switch selector for 4-20mA or 0-10VDC input
- Switch selector for 4-20mA or 0-10VDC position readback
- Switch selector for either "fail in-place" or "fail to zero" upon loss of control signal (provided input power remains)
- On-board push buttons to manually position the actuator
- An adjustable pot for Speed Control (motor pulsing)
- An adjustable pot for deadband adjustment
- A "Mode Selector" switch with LEDs, which are used for:
 - "No tools" pot calibration
 - Setting Zero and Span
 - Manually positioning the actuator
- Locked Rotor Protection if the actuator cannot achieve the position commanded by the control signal, it will cut power to the motor. Repeated stalls will not damage the actuator.
- Reverse acting operation with no rewiring.
- Split range operation with no rewiring.

CS Dimensions

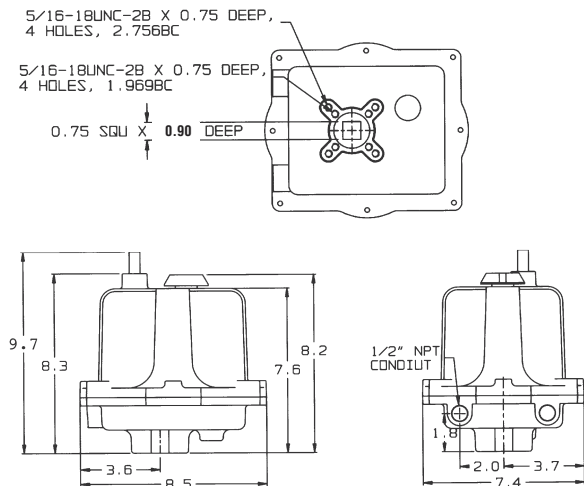

CL Dimensions

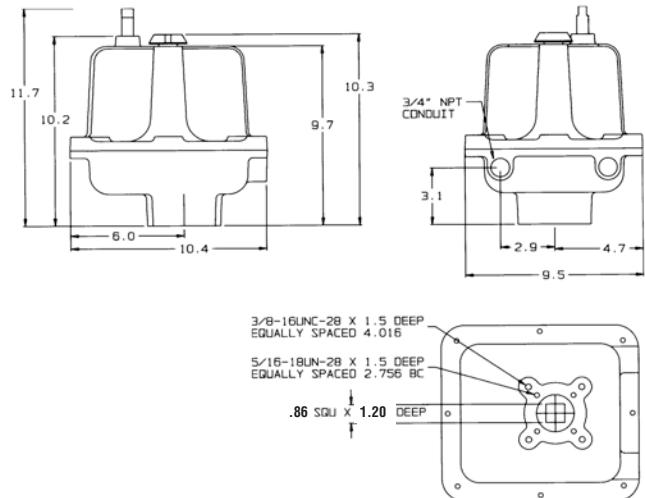

CS & CL Extended Duty Data

TECHNICAL DATA—115VAC AND 230VAC Models*

Torque Output (breakaway)	Speed (seconds per 90° rotation)	Duty Cycle	VA Rating		Max Running Current at Full Load (True RMS)		Max Effective Peak Inrush Current (= .66 x peak inrush)	
			115VAC	230VAC	115VAC	230VAC	115VAC	230VAC
150 in lb	8	75%	70vA	115vA	.6 amps	.5 amps	1.25 amps	.924 amps
300 in lb	15	75%	70vA	115vA	.6 amps	.5 amps	1.25 amps	.924 amps
600 in lb	30	75%	70vA	115vA	.6 amps	.5 amps	1.25 amps	.924 amps
1000 in lb	25	75%	92vA	161vA	.8 amps	.7 amps	1.66 amps	1.29 amps
1500 in lb	40	75%	92vA	161vA	.8 amps	.7 amps	1.66 amps	1.29 amps
2000 in lb	55	75%	92vA	161vA	.8 amps	.7 amps	1.66 amps	1.29 amps
2500 in lb	70	75%	92vA	161vA	.8 amps	.7 amps	1.66 amps	1.29 amps
3000 in lb	75	55%	92vA	161vA	.8 amps	.7 amps	1.66 amps	1.29 amps

CS & CL Continuous Duty Data

Torque (in-lbs)	Duty Cycle	12VDC		24VDC		24VAC		115VAC		230VAC	
		Cycle Time (sec/90°)	Current Draw Amps	Cycle Time (sec/90°)	Current Draw Amps	Cycle Time (sec/90°)	Current Draw Amps	Cycle Time (sec/90°)	Current Draw Amps	Cycle Time (sec/90°)	Current Draw Amps
150	100%	11	2.2	13	1.2	8	1.8	9	0.4	9	0.4
300	100%	17	2.5	13	1.4	12	2.1	13	0.5	13	0.4
600	100%	17	2.8	13	1.7	13	2.5	14	0.6	14	0.5
1000	100%	21	4	14	2.4	15	3.5	15	0.9	15	0.6
1500	100%	40	4	24	2.4	27	3.5	29	0.9	29	0.6
2000	100%	40	4.3	33	2.4	28	3.5	29	0.9	29	0.6
2500	100%	55	3.3	40	2	38	3.1	39	0.8	39	0.6
3000	100%	60	3.7	42	2.2	40	3.5	42	0.8	43	0.6

*Notes:

- The Current Draws stated above include all options. If the brake and/or heater & thermostat are not installed, the actual current draws will be less.
- For Extended Duty Cycle Models, Current Draws are provided at full running torque. If the actuator encounters an overtorque condition, such as a stall condition, the Current Draw will be vastly increased.
- "Continuous Duty actuators contain brushless DC motors and are therefore not limited by duty cycle restraints in environments at or below 104°F; in ambient environments above this temperature the duty cycle is de-rated to 80%."

ACTUATOR MODEL #'s/DESCRIPTION

230 VAC	230 VAC MOTOR
24 VAC	24 VAC MOTOR (1) (Continuous Duty only)
12/24 VDC	12 OR 24 VDC MOTOR (Continuous Duty only)
X	NEMA 4,4X,7, & 9
W	NEMA 4 & 4X
H	TROPICAL HEATER
S2	TWO AUXILIARY SWITCHES SPDT
T	HEATER AND THERMOSTAT
K	MOTOR BRAKE(2)
Z	DECLUTCHABLE HANDWHEEL OVERRIDE

(1) NOT AVAILABLE WITH CSA LISTING. CONTACT FACTORY FOR CSA LISTING ON OPTION COMBINATIONS

(2) NOT REQUIRED ON CONTINUOUS DUTY CYCLE UNITS

CONTROL OPTIONS FOR CONTINUOUS DUTY CYCLE*

R2	SINGLE RELAY 2 WIRE CONTROL
C	POSITIONER (SPECIFY SIGNAL)**
CL2	POSITIONER WITH FAIL SAFE BACKUP FOR CS SERIES(1)
CL3	POSITIONER WITH FAIL SAFE BACKUP FOR CL SERIES(1)
L2	FAIL SAFE BATTERY BACKUP FOR CS SERIES***(1)
L3	FAIL SAFE BATTERY BACKUP FOR CL SERIES***(1)
J	SPEED CONTROL/TIMER BOARD/3 WIRE RELAY (Extended Duty only)

NOTE: NO MANUAL OVERRIDE ON FAILSAFE UNITS

*CONTACT ACTUATOR ENGINEERING FOR APPLICATIONS NOT COVERED BY INDICATED OPTIONS

*OPTION AVAILABILITY AND PRICES ARE SUBJECT TO CHANGE WITHOUT NOTICE

**OPTION "C" INCLUDES POSITION TRANSMITTER & CYCLE RATE REGULATOR

***OPTION "CL2", "CL3", "L2", & "L3" INCLUDE POSITION TRANSMITTER

A BOARD OPTION MUST BE SELECTED WITH CONTINUOUS DUTY CYCLE. ONLY ONE BOARD OPTION CAN BE INSTALLED IN THE ACTUATOR.

How To Order Examples

ACTUATOR MODEL	TORQUE	ENCLOSURE	OPTIONS	VOLTAGE
CS XXX	600	W-NEMA IV	C (POSITIONER)	115VAC
CL XXX	2500	W-NEMA IV	S2 (TWO SWITCHES)	230 VAC