



77-200 Series

Bronze Full Port Solder End Ball Valve

Solder End, 600 psig WOG, Cold Non-Shock. 150 psig Saturated Steam. (See referenced P/T chart)
 Vacuum Service to 29 inches Hg.

Federal Specification: WW-V-35C, Type: II, Composition: BZ, Style: 3.

MSS SP-110; Ball Valves Threaded, Socket-Welding, Solder Joint, Grooved and Flared Ends.

FEATURES

- Two-piece body
- Reinforced seats
- Full port for full flow & min. pressure drop
- Blow-out-proof stem design
- Adjustable packing gland

STANDARD MATERIAL LIST

1. Lever and grip	Steel, zinc plated w/vinyl	7. Gland nut	B16
2. Stem packing	MPTFE	8. Stem	B16
3. Stem bearing	RPTFE	9. Lever nut	Steel, zinc plated
4. Ball	B16 chrome plated	10. Body seal	PTFE
5. Seat (2)	RPTFE	11. Body	B584-C84400
6. Retainer	B16 (3/4" to 1") B584-C84400 (1-1/4" to 2-1/2")		

VARIATIONS AVAILABLE:

77-240 Series (316 SS Ball & Stem)

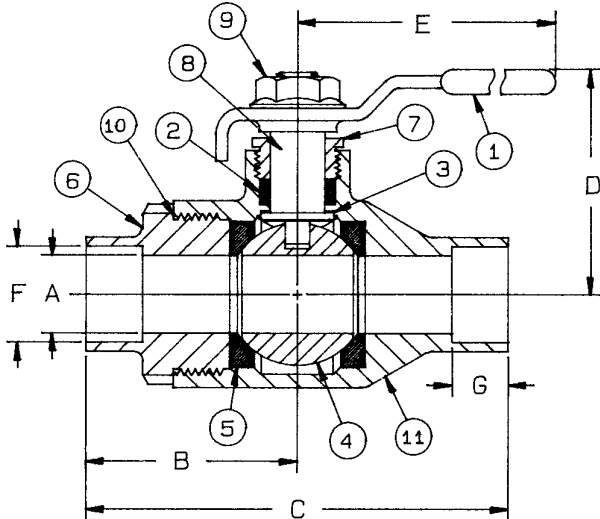

The 77-200 is designed to be soft soldered into lines without disassembly. This allows a tested valve to be installed without disturbing the seats and seals in any way. Soldering temperature not to exceed 500°F.

OPTIONS AVAILABLE:

(SUFFIX)	OPTION	SIZES
-02	Stem Grounded	3/4" to 2-1/2"
-03	1-1/4" CS Stem Extension	3/4" to 2-1/2"
-04	2-1/4" CS Stem Extension	3/4" to 2-1/2"
-05	Plain Ball	3/4" to 2-1/2"
-07	Steel Tee Handle	3/4" to 1-1/4"
-08	90° Reversed Stem	3/4" to 2-1/2"
-10	SS Lever & Nut	3/4" to 2-1/2"
-11	Therma-Seal™ Insulating Tee Handle	3/4" to 2"
-14	Side Vented Ball (Uni-Directional)	3/4" to 2-1/2"
-15	Wheel Handle, Steel	3/4" to 1-1/4"
-16	Chain Lever - Vertical	3/4" to 2-1/2"
-17	Rough Chrome Plated - Bronze Valves	3/4" to 2-1/2"
-20	Slot Vented Ball	3/4" to 2-1/2"
-24	Graphite Packing	3/4" to 2-1/2"
-27	SS Latch-Lock Lever & Nut	3/4" to 2-1/2"
-30	Cam-Lock and Grounded	3/4" to 1-1/4"
-32	SS Tee Handle & Nut	3/4" to 1-1/4"
-35	VTPE Trim	3/4" to 2-1/2"
-40	Cyl-Loc and Grounded	3/4" to 1-1/4"
-45	Less Lever & Nut	3/4" to 2-1/2"
-46	Latch Lock Lever - Lock in Closed Position Only	3/4" to 2-1/2"
-47	SS Oval Latch-Lock Handle & Nut	3/4" ONLY
-48	SS Oval Handle (No Latch) & Nut	3/4" to 2-1/2"
-49	Assembled Dry	3/4" to 2-1/2"
-50	2-1/4" CS Locking Stem Extension	3/4" to 2-1/2"
-56	Multifill Seats & Packing	3/4" to 2-1/2"
-57	Oxygen Cleaned	3/4" to 2-1/2"
-58	Chain Lever - Horizontal	3/4" to 2-1/2"
-60	Static Grounded Ball & Stem	3/4" to 2-1/2"
-63	NPT x Solder/Socket Weld	3/4" to 2-1/2"
-92	Balancing Stop	3/4" to 2-1/2"

BRONZE FULL PORT SOLDER END BALL VALVE

NUMBER	SIZE	A	B	C	D	E	F	G	Wt.
77-204-01	3/4"	.81	2.28	4.28	2.12	4.87	.878	.75	1.65
77-205-01	1"	1.00	2.72	4.64	2.62	5.50	1.129	.90	2.99
77-206-01	1-1/4"	1.25	2.60	5.15	2.87	5.50	1.378	.96	4.55
77-207-01	1-1/2"	1.50	3.00	6.00	3.34	8.00	1.629	1.09	6.04
77-208-01	2"	2.00	3.62	7.24	3.71	8.00	2.129	1.34	10.58
77-209-01	2-1/2"	2.50	3.93	7.87	4.12	8.00	2.630	1.48	15.53

For Pressure/Temperature Ratings,
 Refer to Page M-8, Graph No. 4