

- 11) With the ball in the closed position, thread the retainer into the body and torque to manufacturing specification to secure the body joint. Tighten to the torque values shown in the table below.
- 12) Cycle the valve to the open position and verify proper operation and alignment of handle and/or mechanism.

**Note: Always test valve and system before putting the system into service.**

**Table 1: Torque Requirements**

Gland Nut Torque (+ or - 10%) (ft-lb)	Retainer Torque (+ or - 10%) (ft-lb)	Valve Size	Gland Nut Torque (+ or - 10%) (ft-lb)	Retainer Torque (+ or - 10%) (ft-lb)
<b>BRONZE</b>			<b>STEEL</b>	
10 - 12	13	1/4" - 3/8"	12 - 18	13
10 - 12	16	1/2"	12 - 18	16
15 - 20	42	3/4"	20 - 25	42
15 - 20	63	1"	20 - 25	63
35 - 40	130	1-1/4"	61-100	130
35 - 40	199	1-1/2"	61-100	199
35 - 40	282	2"	61-100	282
35 - 40	686	2-1/2"	61-100	681
35 - 40	905	3"	61-100	905
35 - 40	1849	4"	-	-

**PARTS ILLUSTRATION**

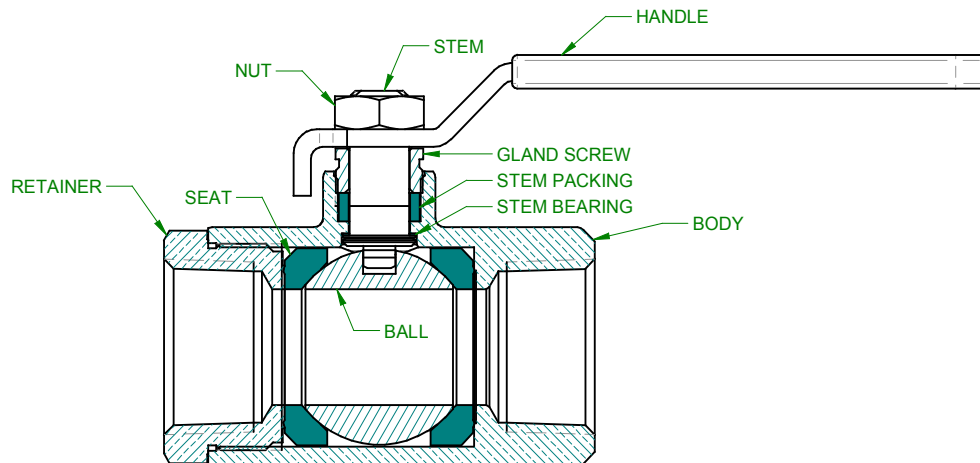

A Division of Conbraco Industries, Inc. Matthews, NC Pageland, SC Conway, SC

## 3 - WAY DIVERSION BALL VALVES 70600, 70900 and 76600 SERIES INSTALLATION, OPERATION, & MAINTENANCE GUIDE

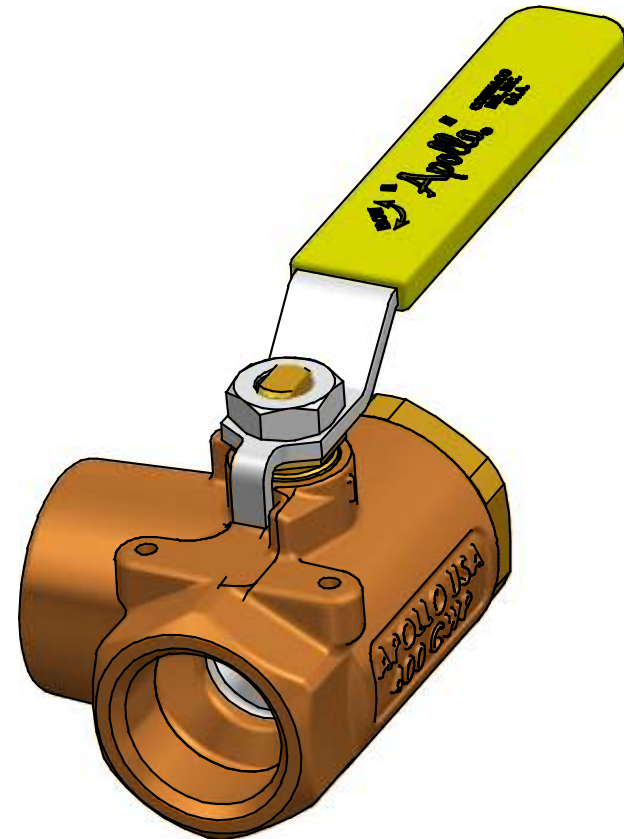

## INSTALLATION

The 3-Way threaded and solder end Apollo Ball valves can be used as a mixing or diverting valve.

Note: Valves must be installed in piping systems that comply with the applicable portions of the ASME B31 standards. Special considerations must be taken with respect to pipe line expansions and contractions and the media expansion and contractions within the piping system.

### Threaded End Valves

Pipe connections to be threaded into these valves should be accurately threaded, clean and free of foreign material or metal shavings. PTFE pipe tape is recommended for use as the pipe joint sealant. Two wrenches must be used when making up pipe joints to these valves. Apply one wrench on the valve end closest to the pipe joint being tightened and the other wrench to the pipe to prevent transmitting torque through the valve body joint. Typical pipe make-up is 1-1/2 turns after installing the pipe hand-tight.

### Solder End (Sweat In) Valves

Caution: Use only solders with melt points below 500°F.

Caution: Valves should only be soldered in the fully open position.

During soldering, the mid-portion of the valve body should not exceed 300°F. This can be monitored using Tempilstik® or an infra-red temperature sensor. Depending on the fuel selected and the orientation of the installation it may be necessary to wrap the valve body with wet rags or employ other heat absorbing techniques. The flame must be directed away from the valve body, concentrated on the solder cup. The cup should be heated evenly. Once one of the joints is complete, the valve should be allowed to cool until "cool to the touch" before beginning the second joint.

Fuel	Flame temp w/Oxygen
Propane	5122°F (2828°C)
Propylene	5245°F (2896°C)
MAPP Gas	5389°F (2976°C)
Acetylene	5720°F (3160°C)

Warning: Excessive heat input will damage the body seal resulting in leaks at the valve body joint. In extreme cases, seats and stem packing may also be damaged.

## OPERATION

The valve handle is marked showing proper "FLOW" direction in respect to handle position at extreme end of handle travel.

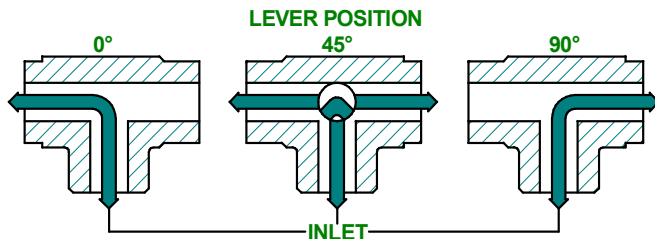

## MAINTENANCE

### Regular Maintenance

Normal stem packing wear can be compensated for by tightening the packing gland screw. (Wrench part number H371400 is available to ease this operation.) Tighten the packing gland screw clockwise in 1/8 turn increments until observed leakage stops. Do not exceed the values shown in Table 1. If all of the adjustments to the packing gland screw have been made, remove the handle nut, handle and packing gland screw and add one or two replacements bearings on top of the old packing. Reinstall the handle and handle nut.

Caution: Do not disassemble valve while under pressure nor with entrapped hazardous fluids therein.

### Valve Repair

#### Disassembly

- 1) Operate the valve 0° to 90° to assure there are no trapped fluids or pressure in the body cavity. Place the handle in the position such that it is parallel to the inlet port.
- 2) Remove the handle nut, handle and packing nut. Set aside for reuse.
- 3) Install pipe plugs in the body and retainer ports of NPT valves to prevent collapsing those areas.
- 4) Remove the retainer from the body. It may be necessary to heat the body joint above 450°F to breakdown the sealant used to secure the valve halves.
- 5) Remove the ball from the body cavity. Inspect the ball. If it is scarred, it is recommended that the whole valve be replaced, but replacement balls are available. Clean and set aside good balls for reuse.
- 6) Push the stem from the outside into the body cavity. Inspect the stem. If it is scarred or has damaged threads, replacements are available. Clean and set aside good stems for reuse.
- 7) Remove all seals and seats from the body and retainer then discard. Inspect the body and retainer for damage. If damaged, scrap the valve as replacements of these components are not offered.

#### Re-Assembly

- 1) Install stem bearing on to stem.
- 2) Fit stem into body from the retainer end and position the stem with the handle flats perpendicular to the flow axis.
- 3) Install stem packing over stem and fit into body recess.
- 4) Install packing gland screw into the threaded stem area.
- 5) Tighten the gland screw to torque specifications shown in the table of Page 4.
- 6) Install the handle and handle retaining hardware.
- 7) Apply suitable light lubricant to seat and fit into the seat pocket of the body.
- 8) Install the ball. Make sure that the handle is parallel to the inlet port.
- 9) Apply suitable light lubricant to seat and fit into the seat pocket of the retainer.
- 10) Apply an adequate amount of thread locking compound (Loctite® 609, 648 or 680) to the retainer threads so that it covers no less than two complete threads opposite of the retainer shoulder.

**Note: Valves in oxygen service can only be sealed with oxygen compatible thread sealant.**