



70-400 Series



Single Union End Solder Bronze Ball Valve

Solder Ends, Single Union End, 600 psig WOG, Cold Non-Shock.

150 psig Saturated Steam, Vacuum Service to 29 inches Hg.

Federal Specification: WW-V-35C, Type: II, Composition: BZ, Style: 3.

MSS SP-110; Ball Valves Threaded, Socket-Welding, Solder Joint, Grooved and Flared Ends.

FEATURES

- Reinforced seats
- Fluorocarbon O-Ring sealed single union requires only light torque to seal
- Blow-out-proof stem design
- Adjustable packing gland

STANDARD MATERIAL LIST

1. Lever and grip	Steel, zinc plated w/vinyl	8. Stem	B16
2. Stem packing	MPTFE	9. Lever nut	Steel, zinc plated
3. Stem bearing	RPTFE	10. Body seal (1-1/4" to 2")	PTFE
4. Ball	B16, chrome plated	11. Body	B584-C84400
5. Seat (2)	RPTFE	12. Tailpiece	B16 or B584-C84400
6. Retainer	B16 or B584-C84400	13. Union nut	B16 or B584-C84400
7. Gland nut	B16	14. Union seal	Fluorocarbon

VARIATIONS AVAILABLE:

70-440 Series (316 SS Ball & Stem)

The 70-400 is designed to be soft soldered into lines without disassembly. This allows a tested valve to be installed without disturbing the seats and seals in any way. Soldering temperature not to exceed 500°F.

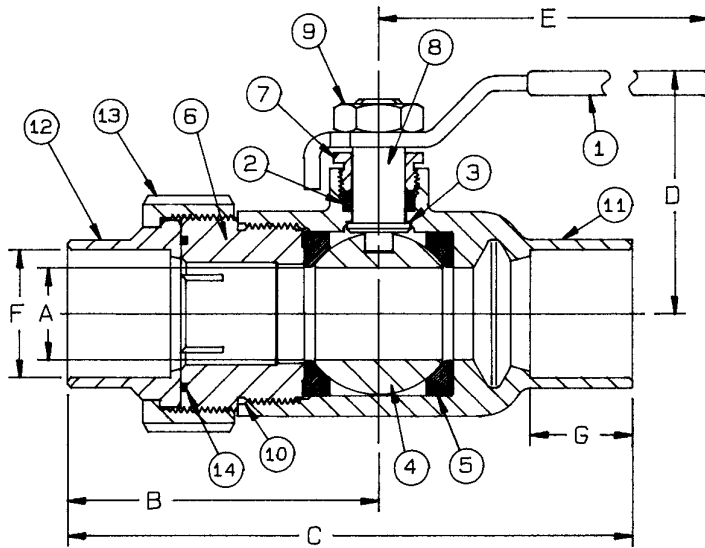

SINGLE UNION END
SOLDER BRONZE BALL VALVE

NUMBER	SIZE	A	B	C	D	E	F	G	Wt.
70-402-01	3/8"	.37	1.81	3.09	1.75	3.87	.503	.37	.85
70-403-01	1/2"	.50	2.00	3.43	1.75	3.87	.628	.50	1.02
70-404-01	3/4"	.68	2.62	4.56	2.06	4.78	.878	.75	1.93
70-405-01	1"	.87	2.81	5.06	2.25	4.78	1.129	.90	2.42
70-406-01	1-1/4"	1.00	2.87	5.18	2.62	5.50	1.378	.96	4.11
70-407-01	1-1/2"	1.25	2.92	5.53	3.10	8.00	1.629	1.09	5.44
70-408-01	2"	1.50	3.50	6.75	3.24	8.00	2.129	1.34	7.77

OPTIONS AVAILABLE:

(SUFFIX)	OPTION	SIZES
-02-	Stem Grounded	3/8" to 2"
-03-	1-1/4" CS Stem Extension	3/8" to 2"
-04-	2-1/4" CS Stem Extension	3/8" to 2"
-05-	Plain Ball	3/8" to 2"
-07-	Steel Tee Handle	3/8" to 2"
-08-	90° Reversed Stem	3/8" to 2"
-10-	SS Lever & Nut	3/8" to 2"
-14-	Side Vented Ball (Uni-Directional)	3/8" to 2"
-15-	Wheel Handle, Steel	3/8" to 2"
-16-	Chain Lever - Vertical	3/4" to 2"
-17-	Rough Chrome Plated - Bronze Valves	3/8" to 2"
-18-	Plain Yellow Grip	3/8" to 2"
-20-	Slot Vented Ball (Bi-Directional) - Bronze Valves	3/8" to 2"
-21-	UHMWPE Seats (Non-PTFE)	3/8" to 2"
-24-	Graphite Packing	3/8" to 2"
-27-	SS Latch-Lock Lever & Nut	3/8" to 2"
-30-	Cam-Lock and Grounded	3/8" to 2"
-32-	SS Tee Handle & Nut	3/8" to 2"
-35-	VTFE Trim	3/8" to 2"
-45-	Less Lever & Nut	3/8" to 2"
-46-	Latch-Lock Lever - Lock in Closed Position Only	3/8" to 2"
-48-	SS Oval Handle (No Latch) & Nut	3/8" to 2"
-49-	Assembled Dry	3/8" to 2"
-50-	2-1/4" CS Locking Stem Extension	3/8" to 2"
-56-	Multifill Seats & Packing	3/8" to 2"
-57-	Oxygen Cleaned	3/8" to 2"
-58-	Chain Lever - Horizontal	3/4" to 2"
-60-	Grounded Ball & Stem	3/8" to 2"
-63-	NPT x Solder/Socket Weld	3/8" to 2"
-92-	Balancing Stop	3/8" to 2"

For Pressure/Temperature Ratings,
Refer to Page M-8, Graph No. 4

400# Bronze P-T Rating (Graph 3)

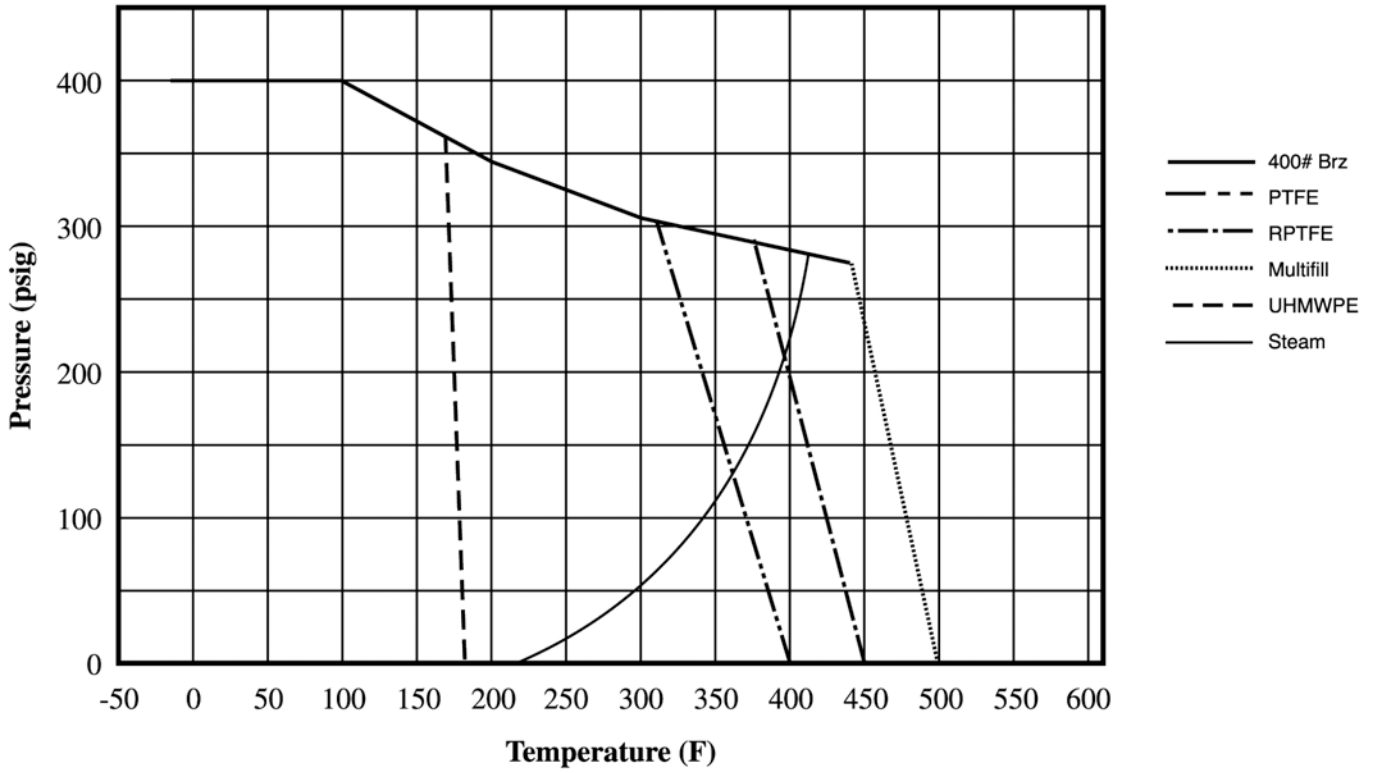

600# Bronze P-T Rating (Graph 4)

