



70-100 SERIES

Standard Port Threaded Ball Valve

Job Name:	Contractor:
Job Location:	P.O. Number:
Engineer:	Representative:
Tag:	Wholesale Distributor:

DESCRIPTION

The Apollo® 70 Series is the most widely used general purpose bronze ball valve in the industry. Trusted performance with a wide range of options.

FEATURES

- Chromium Plated Ball
- Blow-Out-Proof Stem Design
- Adjustable Packing Gland
- RPTFE Seats and Stuffing Box Ring
- 100% Factory Tested

PERFORMANCE RATING

- Maximum Pressure: 600 psi CWP, 150 psi SWP
- Maximum Temperature: 500°F
- Vacuum Service to 29 in. Hg

MODELS

- | | |
|--|----------------------|
| <input type="checkbox"/> 70-140 Series | 316 SS Ball & Stem |
| <input type="checkbox"/> 70-150 Series | Balancing Stop Lever |
| <input type="checkbox"/> 70-190 Series | Pinned Retainer |

STANDARD MATERIALS LIST

Part Name	Material
Lever and Grip	Steel, Zinc Plated w/ Vinyl
Stem Packing	RPTFE
Stem Bearing	RPTFE
Ball	B16, Chrome Plated
Seat (2)	RPTFE
Retainer	B16 (1/4" to 1"), B584-C84400 (1 1/4" to 4")
Gland Nut	B16
Stem	B16
Lever Nut	Steel, Zinc Plated
Body Seal (1 1/4" to 4")	PTFE
Body	B584-C84400

APPROVALS

- MSS SP-110; Ball Valves Threaded, Socket-Welding, Solder Joint, Grooved and Flared Ends
- Federal Specification: WW-V-35C, Type:II, Composition: BZ, Style: 3
- CRN: OC10908.5C



DIMENSIONS

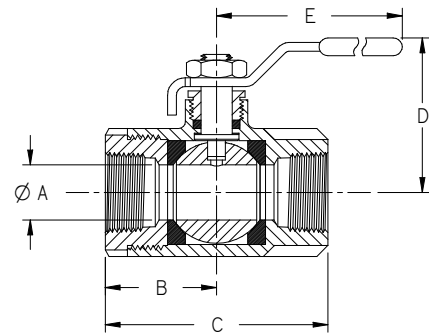

Model Number	Size (in.)	Dimensions					Wt. (lb.)
		A	B	C	D	E	
70-101	1/4"	0.37	1.03	2.06	1.75	3.87	0.60
70-102	3/8"	0.37	1.03	2.06	1.75	3.87	0.56
70-103	1/2"	0.50	1.12	2.25	1.75	3.87	0.63
70-104	3/4"	0.68	1.50	3.00	2.12	4.87	1.39
70-105	1"	0.87	1.68	3.37	2.25	4.87	1.72
70-106	1 1/4"	1.00	2.00	4.00	2.62	5.50	3.26
70-107	1 1/2"	1.25	2.18	4.37	3.06	8.00	4.61
70-108	2"	1.50	2.34	4.68	3.25	8.00	6.06
70-109	2 1/2"	2.00	3.12	6.25	3.72	8.00	17.25
70-100	3"	2.50	3.37	6.75	4.12	8.00	18.60
70-10A	4"	3.12	3.68	7.37	5.25	10.00	25.50

Conbraco Industries, Inc. 701 Matthews Mint Hill Rd. Matthews NC 28106 USA; www.apollovalves.com; 704-841-6000

This specification is provided for reference only. Conbraco reserves the right to change any portion of this specification without notice and without incurring obligation to make such changes to Conbraco products previously or subsequently sold.



70-100 SERIES

Standard Port Threaded Ball Valve

FLOW CHARACTERISTICS

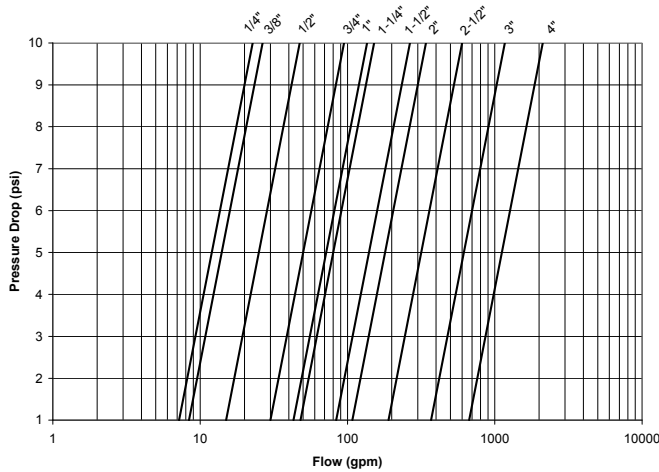

OPTIONS

- | | |
|---|-----------|
| <input type="checkbox"/> (-02) Stem Grounded | 3/4" - 3" |
| <input type="checkbox"/> (-03) 1 1/4" CS Stem Extension | 3/4" - 3" |
| <input type="checkbox"/> (-04) 2 1/4" CS Stem Extension | 3/4" - 3" |
| <input type="checkbox"/> (-05) Plain Ball | 3/4" - 3" |
| <input type="checkbox"/> (-07) Steel Tee Handle | 3/4" - 2" |
| <input type="checkbox"/> (-08) 90° Reversed Stem | 3/4" - 3" |
| <input type="checkbox"/> (-10) SS Lever & Nut | 3/4" - 3" |
| <input type="checkbox"/> (-14) Side Vented Ball (Uni-Directional) | 3/4" - 3" |
| <input type="checkbox"/> (-15) Wheel Handle, Steel | 3/4" - 2" |
| <input type="checkbox"/> (-16) Chain Lever-Vertical | 3/4" - 2" |
| <input type="checkbox"/> (-21) UHMWPE Trim (Non-PTFE) | 3/4" - 3" |
| <input type="checkbox"/> (-24) Graphite Packing | 3/4" - 3" |
| <input type="checkbox"/> (-27) SS Latch-Lck Lever & Nut | 3/4" - 3" |
| <input type="checkbox"/> (-30) Cam-Lock & Grounded | 3/4" - 2" |
| <input type="checkbox"/> (-32) SS Tee Handle & Nut | 3/4" - 2" |
| <input type="checkbox"/> (-35) VTFE Trim | 3/4" - 3" |
| <input type="checkbox"/> (-39) SS Hi-Rise Locking Wheel Handle & Nut | 3/4" - 2" |
| <input type="checkbox"/> (-40) Cyl-Loc & Grounded | 3/4" - 2" |
| <input type="checkbox"/> (-41) Automatic Drain (Bronze Valves Only) | 3/4" - 2" |
| <input type="checkbox"/> (-45) Less Lever & Nut | 3/4" - 3" |
| <input type="checkbox"/> (-46) Latch Lck Lever-Lck Closed Position Only | 3/4" - 3" |
| <input type="checkbox"/> (-47) SS Oval Latch-Lock Handle & Nut | 3/4" - 1" |
| <input type="checkbox"/> (-48) SS Oval Handle (No Latch) & Nut | 3/4" - 2" |
| <input type="checkbox"/> (-49) Assembled Dry | 3/4" - 3" |
| <input type="checkbox"/> (-50) 2-1/4" CS Locking Stem Extension | 3/4" - 3" |
| <input type="checkbox"/> (-56) MPTFE Seats and Packing | 3/4" - 3" |
| <input type="checkbox"/> (-57) Oxygen Cleaned | 3/4" - 3" |
| <input type="checkbox"/> (-58) Chain Lever-Horizontal | 3/4" - 2" |
| <input type="checkbox"/> (-60) Static Grounded Ball & Stem | 3/4" - 3" |
| <input type="checkbox"/> (-64) 250# Steam Trim | 3/4" - 3" |
| <input type="checkbox"/> (-P01) BSPP (Parallel) Thread Connection | 3/4" - 3" |
| <input type="checkbox"/> (-T01) BSPT (Tapered) Thread Connection | 3/4" - 3" |
| <input type="checkbox"/> (-BC) Integral Check Cartridge (250psi max) | 1/2" - 2" |

Conbraco Industries, Inc. 701 Matthews Mint Hill Rd. Matthews NC 28106 USA; www.apollovalves.com ; 704-841-6000

Conbraco Industries can accept no responsibility for possible errors in this document and reserves the right to alter its product design or construction without notice and without incurring any obligation to make such changes on Conbraco products previously or subsequently sold. All product specifications are approximate and are provided for reference only.