

Job Name:	Contractor:
Job Location:	P.O. Number:
Engineer:	Representative:
Tag:	Wholesale Distributor:

DESCRIPTION

The Apollo® Model DC4S (formerly Model DC) Double Check Valves are designed to prevent contamination of the potable water supply due to back-siphonage or backpressure from substances that are non-health hazards. The modular check valves have replaceable seats and reversible EPDM seat discs.

FEATURES

- Lightweight
- Short lay length
- Low pressure loss
- Modular check valves
- Individual access to check valves
- Corrosion resistant epoxy-coated ductile iron body
- US Patents #5,711,341 and #6,343,618
- MADE IN THE USA

MATERIAL SPECIFICATIONS

Part Name	Material
Body	Epoxy-coated (FDA) Ductile Iron
Covers (10")	Epoxy-coated (FDA) Ductile Iron
Check Valves (10")	Bronze
Springs	Stainless Steel
Seat Discs	Chloramine-resistant EPDM

PERFORMANCE RATING

Maximum Working Pressure 175 psi
Temperature Range 33 ° F – 140 ° F
Hydrostatic Test Pressure 350 psi

APPROVALS

ASSE® 1015, CSA® B64.5, IAPMO listed, USC's FCCC&HR, AWWA C-510, UL*, FM*, and the City of New York.

All approvals in horizontal and vertical flow-up configurations.

*UL and FM installations must include indicating-type shut-off valves.



ORDERING INFORMATION

4 S - 1 X X - 0 X X

Y-STRAINER ———
SIZE ———
SHUT-OFF VALVES ———
FLOW (OPTIONAL) ———

Y-STRAINER

- 0 – None (Standard)
- 1 – With Y-Strainer

SIZE

- G – 10"

SHUT-OFF VALVES (Inlet x Outlet)

- 1 – Less Shut-off Valves (flanged-end body)
- 2 – NRS Flanged x NRS Flanged
- 3 – OS&Y Flanged x OS&Y Flanged
- 5 – Epoxy-coated Flanged Ball Valves
- 6 – OS&Y Flg x Post Indicator Flg
- 7 – OS&Y Flg x OS&Y Grv
- 8 – OS&Y Grv x OS&Y Grv
- 10 – OS&Y Flg x Post Indicator Grv

FLOW

- N – N-Flow (with elbows)

DIMENSIONS (in.) – WEIGHTS (lbs.)

Size	10"
A*	55 ¾
B*	29 ½
C (NRS)	26 ½
C (OS&Y Open)	46
D	19 ½
E	16
Test Cocks (NPT)	¾
Net Wt. (Less Valves)	470
Net Wt. (w/ OS&Y shut-off valves)	1320
Net Wt. (w/ OS&Y valves & elbows)	1693

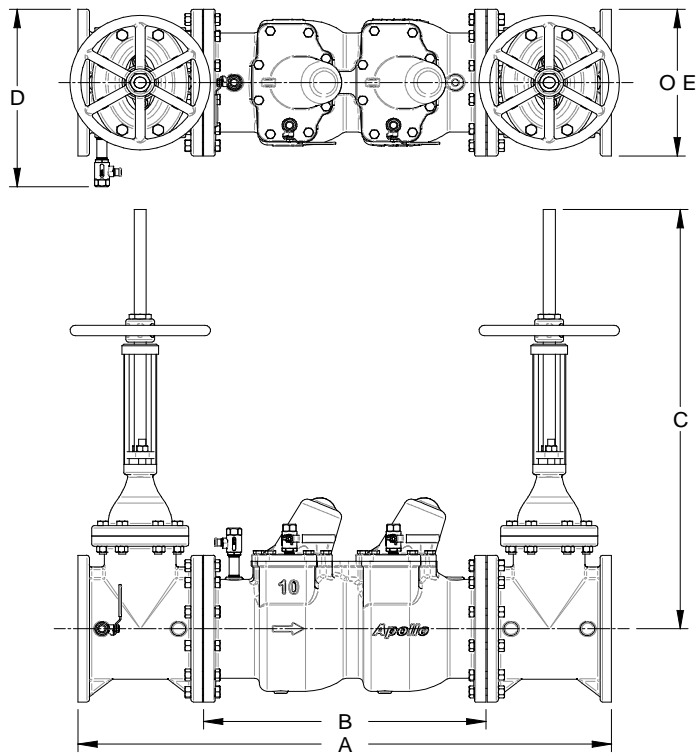

* Nominal dimensions are shown.
Allowances must be made for manufacturers' tolerances.

FLOW CURVE

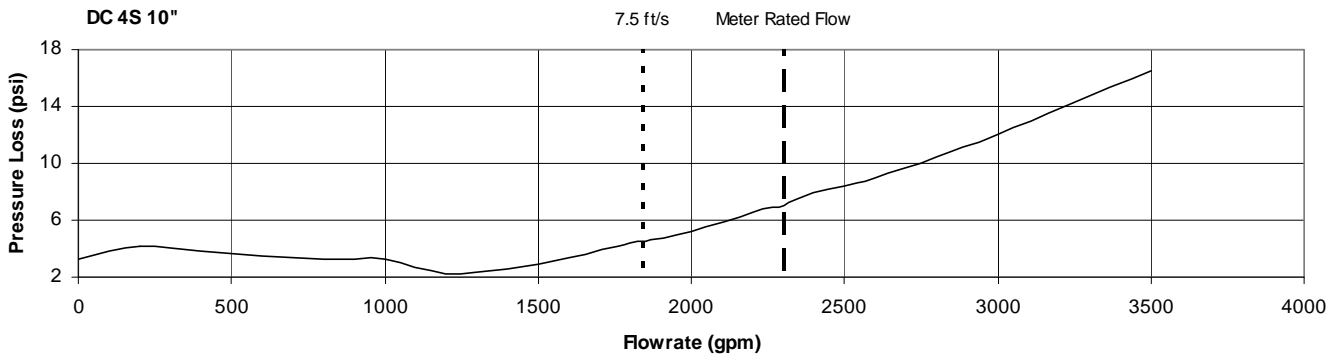

Notes:

1. Flow curves directly reflect data collected by an ASSE approved laboratory.
2. All data points are based on ASSE increasing flow data, from zero GPM to Meter Rated Flow (opening curve).
3. For high flow rates/pressure loss information – contact factory.